

Flex Compact Harsh Environment Individual Node Holder

Date: _____
 Type: _____
 Firm Name: _____
 Project: _____

50 holders, Black

ACCESSORY

The Individual Node Holder allows simple and secure attachment of one Flex Compact Harsh Environment node. Place the node into the base, close the cover over the node, then attach to the structure with (customer supplied) hardware.

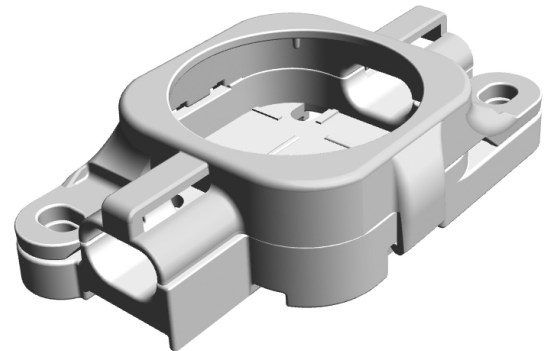

Specifications

Physical

Dimensions	74.6 x 47.6 x 18.7 mm (2.94 x 1.875 x 0.75 in) (Height x Width x Depth)
Weight	.01 kg (.03 lb) each
Housing	Black Polycarbonate

Certification and Safety

Certification	UL, CE
---------------	--------

Individual Node Mount

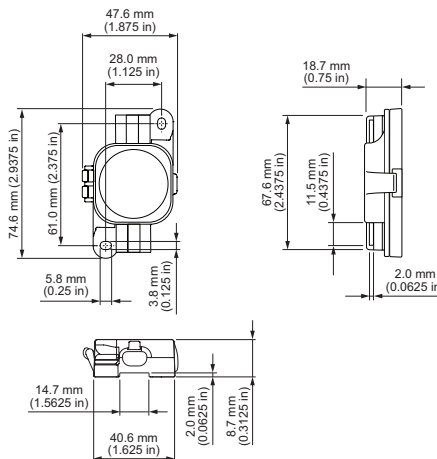

Accessory

Flex Compact Harsh Environment Individual Node Holder
 50 holders, Black

Item Number	Item 12NC
101-000058-31	912400137672

© 2022 Signify Holding. All rights reserved. Specifications are subject to change without notice. No representation or warranty as to the accuracy or completeness of the information included herein is given and any liability for any action in reliance thereon is disclaimed.

11/3/2022

